

This drawing is the sole property of Miether Bearing Products and contains confidential and proprietary information. It is being provided to you for your use and may not be disclosed to any third party or used for any other purpose without Miether's prior written consent. The [materials] must be returned to the Company upon its demand. Your acceptance of these materials constitutes your acceptance of the foregoing terms.

C-14018

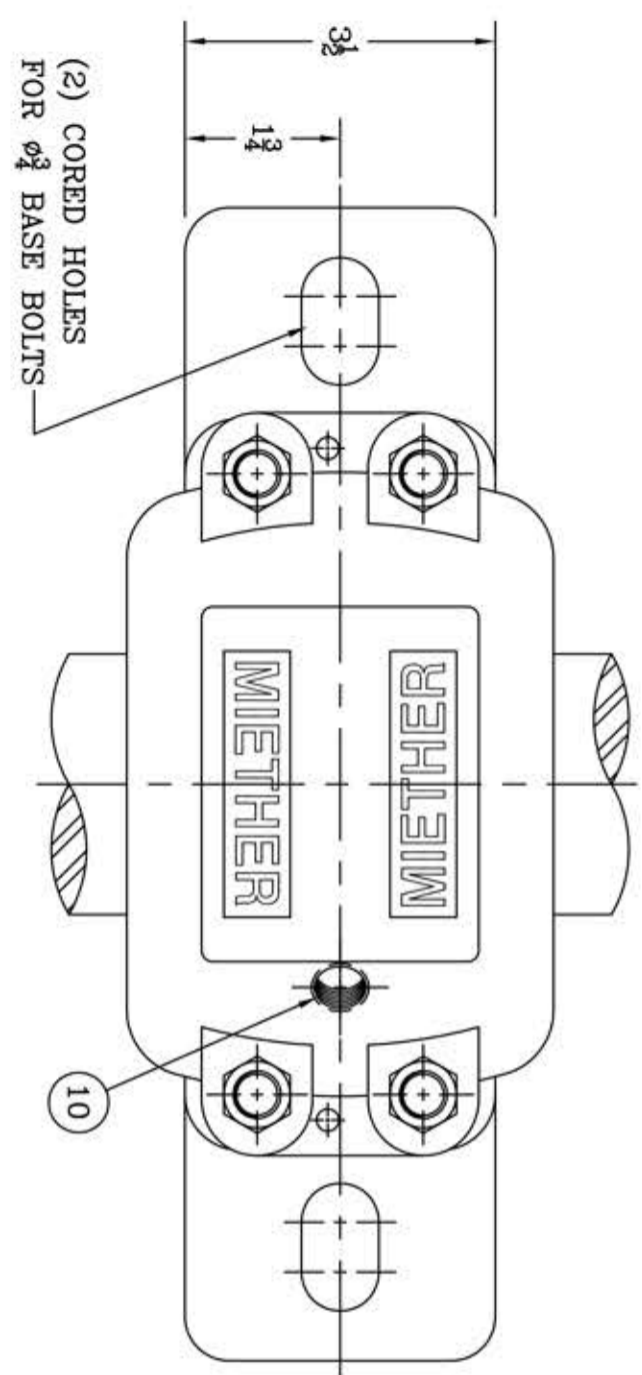

(2) CORED HOLES FOR $\phi 3/4$ BASE BOLTS

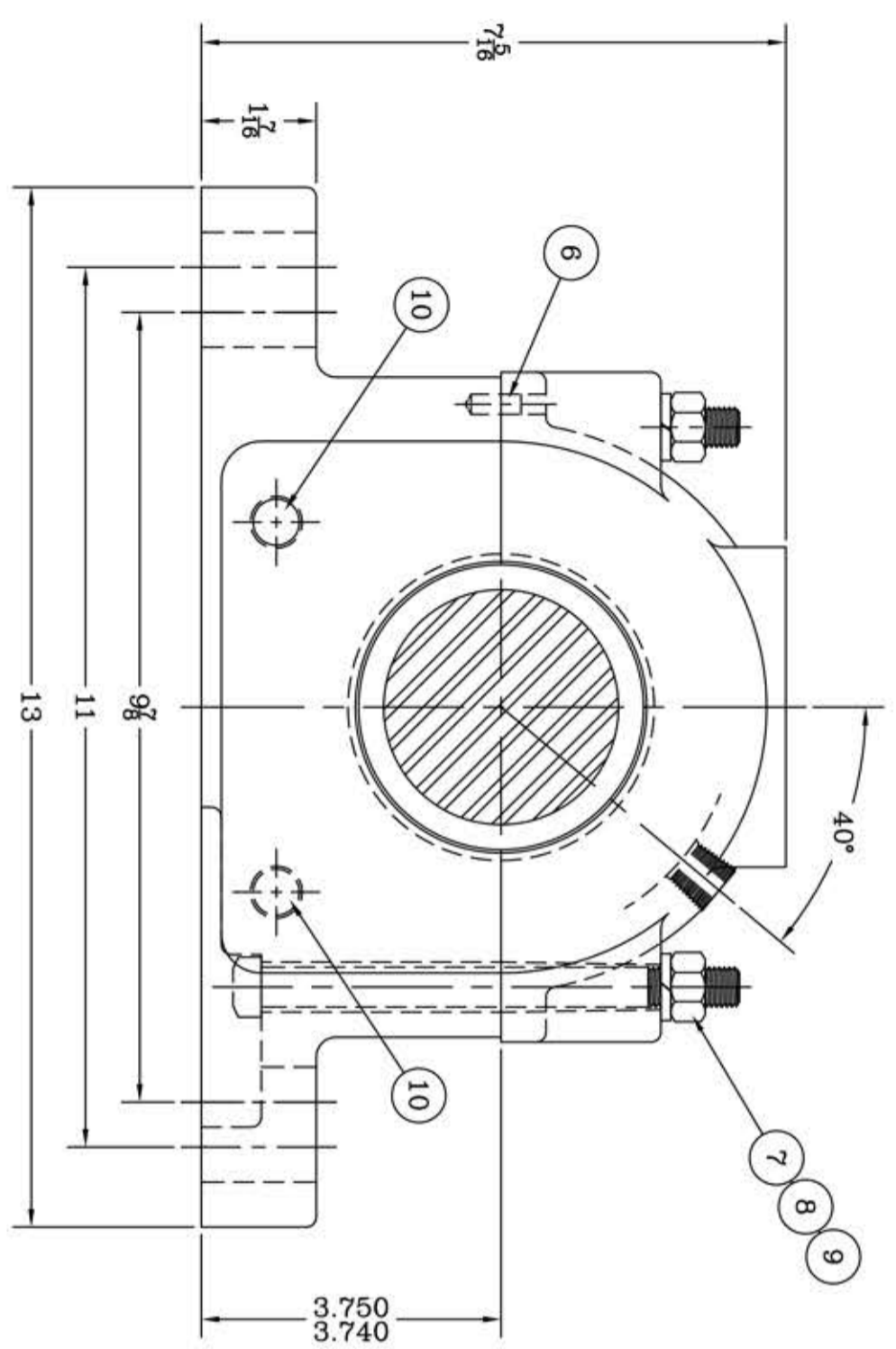

ITEM	DESCRIPTION	DETAIL	REQUIRED
1	HOUSING SAF 517 02-15	C-13149-R	1 1
2	SPHERICAL ROLLER BEARING	22217K/W-33	1 1
3	STABILIZING RING SR-17-14	A-10600	1 0
4	ADAPTER SNW-17 02-15	B-24410	1 1
5	TRIPLE SEAL RING LER-53	A-10985	2 2
6	DOWEL	$\phi 1/4 \times 3/8$ LONG	2 2
7	CAP BOLT SQUARE HEAD	$1/2-13$ NC x 6" LONG	4 4
8	CAP BOLT HEX. NUT	$1/2-13$ NC	4 4
9	LOCKWASHER	$1/2$ SPLT MED.	4 4
10	PIPE PLUG	$3/8-18$ NPT	3 3

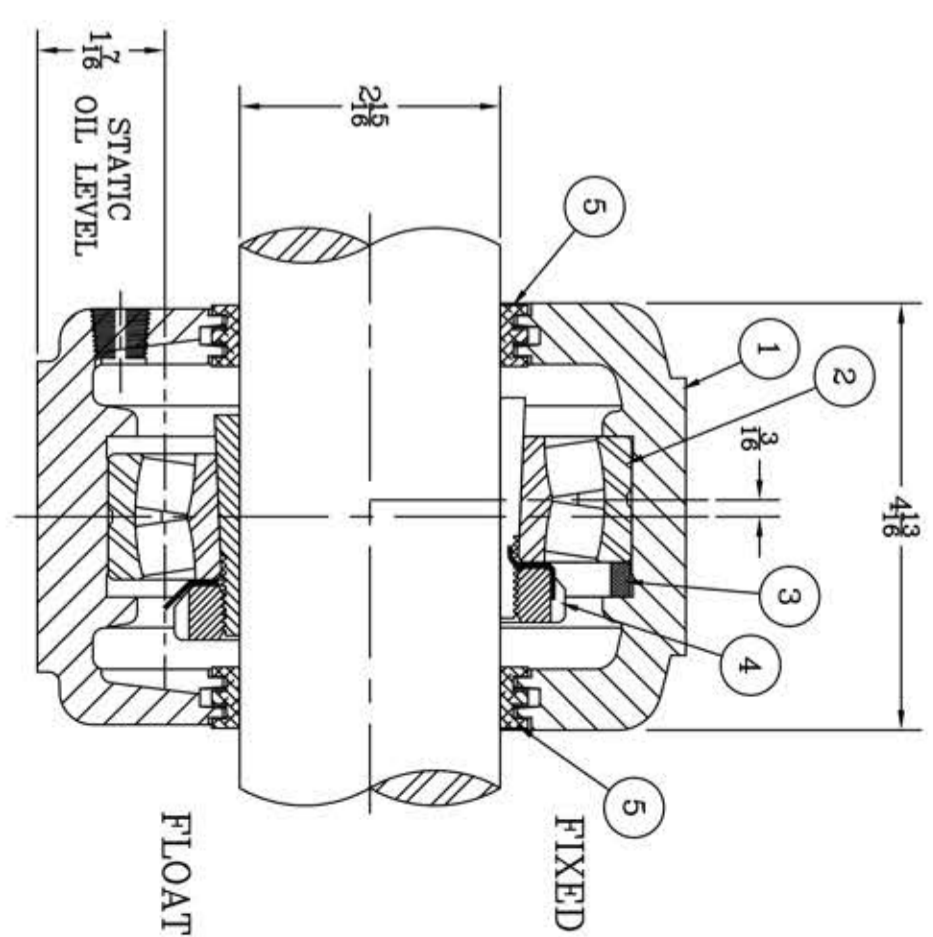

REDRAWN FOR CONFORMITY RWB 1-12-04

REVISIONS

SYMBOL	DESCRIPTION
C	REVISIONS
D	REVISIONS
E	REVISIONS
F	REVISIONS
G	REVISIONS
H	REVISIONS
I	REVISIONS
J	REVISIONS
K	REVISIONS

TOLERANCE: UNLESS OTHERWISE SPECIFIED
 FRACTIONS $\pm 1/32$ "
 DECIMALS $\pm .005$ "
 CASTING $\pm 1/16$ "
 ANGLES $\pm .0^\circ$ - 30°
 WELD $\pm 1/16$ "
 A.I.S.I. STANDARD FINISHES

AN ALCO INDUSTRIES COMPANY
 BEARING PRODUCTS
 ODESSA, TX. USA

SAF 22517 02-15
 ASSEMBLY DRAWING

SCALE 1 = 1.5
 DRAWN GM
 DATE 1/26/70
 CHECK:

ASSEMBLY NO.
 DRAWING NO. C-14018